

1500SJ

TELESCOPIC ULTRA BOOM

BOOM LIFT



KEY SPECS

Platform Height
150-ft / 45.7-m

Drive Speed
3.0 mph / 4.8 km/h

Horizontal Outreach
80-ft / 24.38-m

Platform Capacity
1,000-lb / 454-kg - Restricted
500-lb / 227-kg - Unrestricted

KEY FEATURES

- Experience greater work envelope flexibility and additional outreach at elevation with telescoping jib.
- Carry everything you need right to the job with dual 1,000-lb restricted and 500-lb unrestricted capacities for maximum productivity.
- Designed for ease of transport with no oversized load permit needed (over-weight permit required for highway transportation).
- Single sensor load sensing system features fewer parts and requires no weight to calibrate.

ACCESSORIES & OPTIONS

- Accessory Packages:
 - SkyWelder® Package
 - SkyPower® Package
 - SkyGlazier® Package
- Additional Platform Options
 - Fall Arrest, Rear Entry - 36 x 96-in
 - Drop Bar - 30 x 36-in, 30 x 48-in, 36 x 72-in, 36 x 96-in
 - Inward Self-Closing Swing Gate - 30 x 48-in, 36 x 72-in, 36 x 96-in
 - Tri-Entry, Drop Bar - 36 x 72-in, 36 x 96-in
 - Tri-Entry, Swing Gate - 36 x 72-in, 36 x 96-in
 - Amber Beacon
 - Ambient White Noise Alarm
 - Bolt On Fall Arrest System
 - ClearSky™ Telematics
 - Cold Package Plus¹
 - Cold Weather Start Kit²
 - Hostile Environment Kit³
 - Light Package⁴
 - Platform Mesh, Bolt On
 - Mesh to Top Rail, Plastic or Aluminum
 - Mesh to Mid Rail, Plastic or Aluminum
 - SkySense® Enhanced Detection System
 - Soft Touch System
 - Special Hydraulic Oils
 - Platform Storage Tray, Center or Corner

STANDARD SPECIFICATIONS

Performance

Platform Height	150-ft / 45.7-m
Horizontal Outreach	80-ft / 24.38-m
Swing	360 Degrees Continuous
Platform Capacity (Restricted)	1,000-lb / 454-kg
Platform Capacity (Unrestricted)	500-lb / 227-kg
Platform Rotator	180 Degrees Hydraulic
Jib Length (Retracted)	15-ft 2-in / 4.62-m
Jib Length (Extended)	25-ft / 7.62-m
Jib Range of Articulation	120 Degrees (+75, -45)
Weight*	48,000-lb / 21,772-kg
Max. Ground Bearing Pressure	113 psi / 7.94 kg/cm ²
Drive Speed	3.0 mph / 4.8 km/h
Gradeability	40%
Tilt Cut Out	4 Degrees
Turning Radius (Inside):	
Axles (Retracted/Extended)	14-ft 5-in (4.39-m) / 8-ft (2.44-m)
Turning Radius (Outside):	
Axles (Retracted/Extended)	22-ft 6-in (6.86-m) / 19-ft 4-in (5.89-m)

*Certain options or country standards increase weight

Engine

Diesel Engine – Deutz TD2.9L4 Tier 4 Final	74.2 hp / 55.4 kW
Fuel Tank Capacity	31 gal / 117.35 L

Tires

Standard	445/50D710 Foam-filled
----------	------------------------

Hydraulic System

Capacity	55 gal / 208.2 L
----------	------------------

STANDARD FEATURES

- 12V-DC Auxiliary Power
- 173 Degrees Hydraulic Platform Rotator
- 3 Selectable Steering Modes
- AC Receptacle in Platform
- All Motion Alarm
- Control ADE® System
- Drive-Out Extendable Axles
- Engine Distress Warning/Shutdown—Selectable via JLG Analyzer
- Full-Time 4WD
- Glow Plugs
- Gull-Wing Steel Hoods
- Hourmeter
- Lifting/Tie Down Lugs
- Load Sensing System
- LCD Panel at Operator's Platform Control Console
- Platform 36 x 96-in (.91 x 2.44-m) Side Entry
- Proportional Controls
- Platform Console Machine Status Light Panel*
- Selectable Capacity Envelope
- Swing-Out Engine Tray
- SkyGuard SkyLine™
- Tilt Light and Alarm

1. Includes extreme cold engine oil, fuel conditioner, engine block heater, battery blanket, glow plugs, hydraulic tank heater, and oversized footswitch.
 2. Includes battery heater and oil tank heater.
 3. Includes console cover, boom wipers and cylinder bellows.
 4. Includes platform work lights, head and tail lights, amber beacon.

* Provides indicator lights at platform control console for system distress, fuel level, low fuel, 5 degree tilt light and foot switch status.

Additional accessories and options available via JLG Aftermarket.

1500SJ

TELESCOPIC ULTRA BOOM

BOOM LIFT



DIMENSIONS

All dimensions are approximate

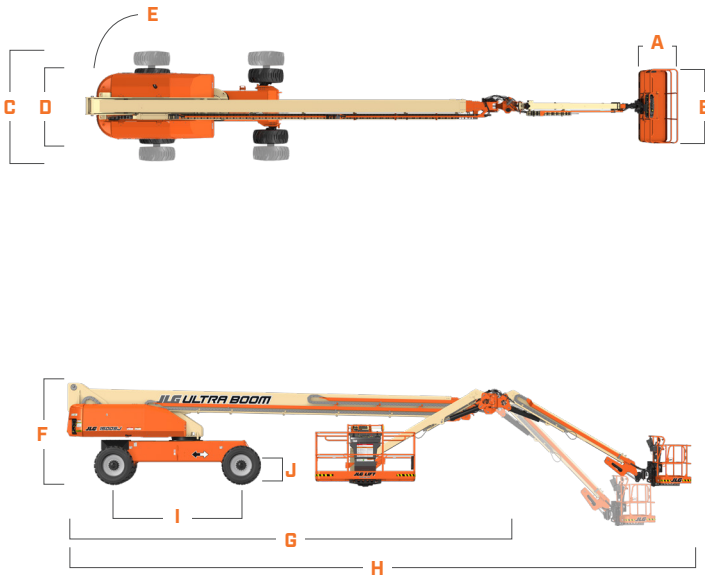

A. Platform Width	36-in / 91-cm
B. Platform Length	96-in / 2.44-m
C. Machine Width - Axles Extended	12-ft 6-in / 3.81-m
D. Machine Width - Axles Retracted	8-ft 2-in / 2.49-m
E. Tailswing	5-ft 6-in / 1.67-m
F. Machine Height	10-ft / 3.05-m
G. Machine Length - Stowed	43-ft / 13.11-m
H. Machine Length - Overall	61-ft 9-in / 18.81-m
I. Wheelbase	12-ft 6-in / 3.81-m
J. Ground Clearance	12-in / 30-cm - Axle 25.5-in / 65-cm - Chassis

REACH DIAGRAM

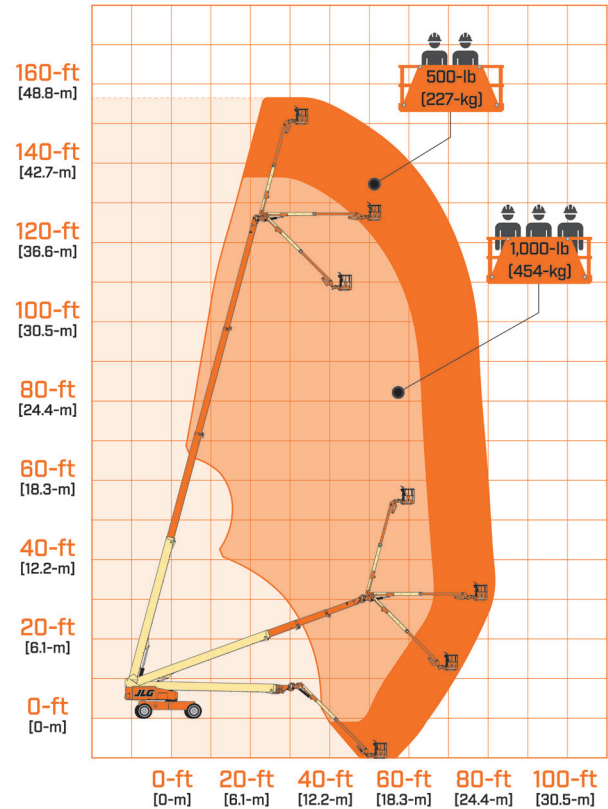

We provide coverage for one (1) full year, and cover all specified major structural components for five (5) years. Due to continuous product improvements, we reserve the right to make specification and/or equipment changes without prior notification. This machine meets or exceeds applicable ANSI and CSA requirements based on machine configuration as originally manufactured for intended applications. Please reference the serial number plate on the machine for additional information.



JLG INDUSTRIES, INC.
Toll-free US 877-JLG-LIFT
JLG.com

An Oshkosh Corporation Company